

CHAPTER 10

Light – Reflection and Refraction

Multiple Choice Questions

- Which of the following can make a parallel beam of light when light from a point source is incident on it?
 - Concave mirror as well as convex lens
 - Convex mirror as well as concave lens
 - Two plane mirrors placed at 90° to each other
 - Concave mirror as well as concave lens
- A 10 mm long awl pin is placed vertically in front of a concave mirror. A 5 mm long image of the awl pin is formed at 30 cm in front of the mirror. The focal length of this mirror is
 - 30 cm
 - 20 cm
 - 40 cm
 - 60 cm
- Under which of the following conditions a concave mirror can form an image larger than the actual object?
 - When the object is kept at a distance equal to its radius of curvature
 - When object is kept at a distance less than its focal length
 - When object is placed between the focus and centre of curvature
 - When object is kept at a distance greater than its radius of curvature
- Figure 10.1 shows a ray of light as it travels from medium A to medium B. Refractive index of the medium B relative to medium A is
 - $\sqrt{3}/\sqrt{2}$
 - $\sqrt{2}/\sqrt{3}$
 - $1/\sqrt{2}$
 - $\sqrt{2}$

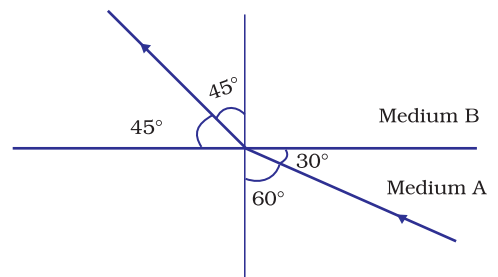

Fig. 10.1

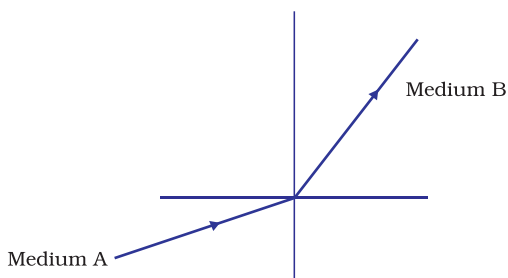

Fig. 10.2

5. A light ray enters from medium A to medium B as shown in Figure 10.2. The refractive index of medium B relative to A will be
- greater than unity
 - less than unity
 - equal to unity
 - zero

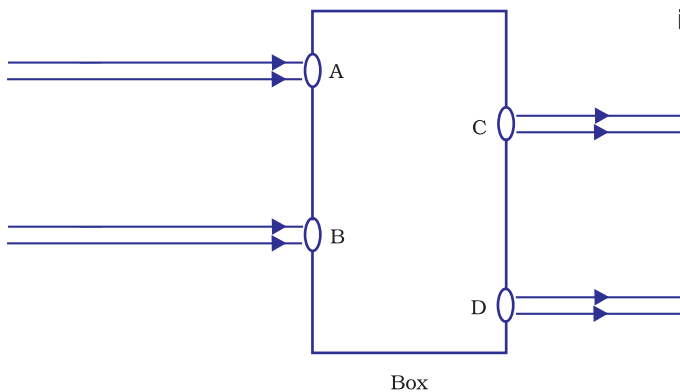

Fig. 10.3

- A rectangular glass slab
- A convex lens
- A concave lens
- A prism

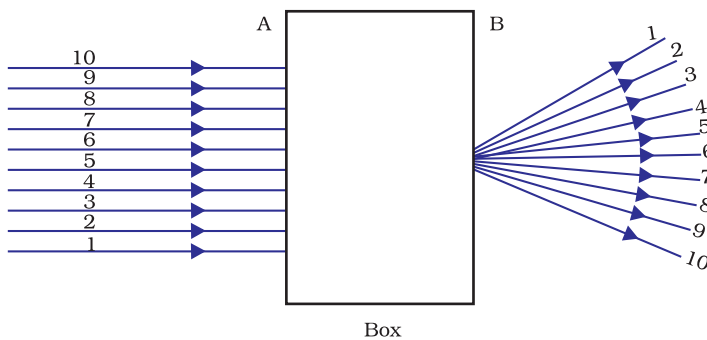

Fig. 10.4

7. A beam of light is incident through the holes on side A and emerges out of the holes on the other face of the box as shown in the Figure 10.4. Which of the following could be inside the box?

- Concave lens
- Rectangular glass slab
- Prism
- Convex lens

8. Which of the following statements is true?

- A convex lens has 4 dioptre power having a focal length 0.25 m
- A convex lens has -4 dioptre power having a focal length 0.25 m
- A concave lens has 4 dioptre power having a focal length 0.25 m
- A concave lens has -4 dioptre power having a focal length 0.25 m

- 9.** Magnification produced by a rear view mirror fitted in vehicles
- is less than one
 - is more than one
 - is equal to one
 - can be more than or less than one depending upon the position of the object in front of it
- 10.** Rays from Sun converge at a point 15 cm in front of a concave mirror. Where should an object be placed so that size of its image is equal to the size of the object?
- 15 cm in front of the mirror
 - 30 cm in front of the mirror
 - between 15 cm and 30 cm in front of the mirror
 - more than 30 cm in front of the mirror
- 11.** A full length image of a distant tall building can definitely be seen by using
- a concave mirror
 - a convex mirror
 - a plane mirror
 - both concave as well as plane mirror
- 12.** In torches, search lights and headlights of vehicles the bulb is placed
- between the pole and the focus of the reflector
 - very near to the focus of the reflector
 - between the focus and centre of curvature of the reflector
 - at the centre of curvature of the reflector

- 13.** The laws of reflection hold good for
- plane mirror only
 - concave mirror only
 - convex mirror only
 - all mirrors irrespective of their shape

- 14.** The path of a ray of light coming from air passing through a rectangular glass slab traced by four students are shown as A, B, C and D in Figure 10.5. Which one of them is correct?

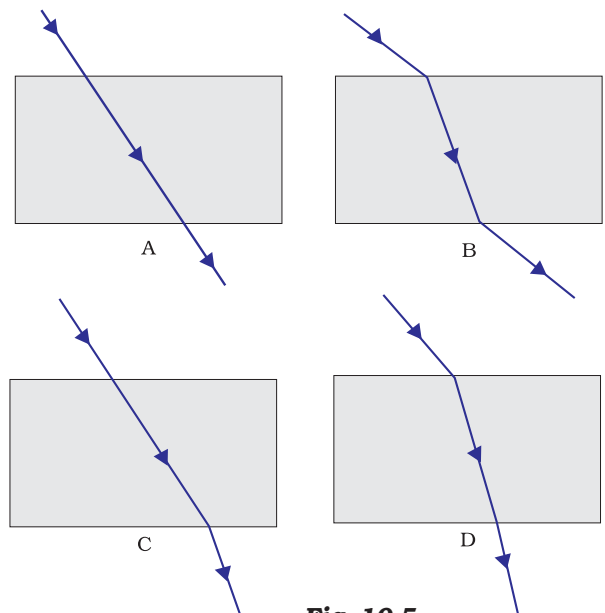

Fig. 10.5

- A
- B
- C
- D

15. You are given water, mustard oil, glycerine and kerosene. In which of these media a ray of light incident obliquely at same angle would bend the most?

- (a) Kerosene
- (b) Water
- (c) Mustard oil
- (d) Glycerine

16. Which of the following ray diagrams is correct for the ray of light incident on a concave mirror as shown in Figure 10.6?

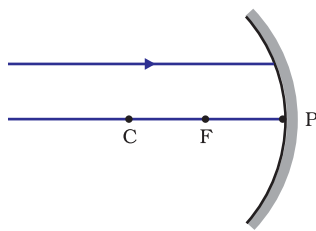

Fig. 10.6

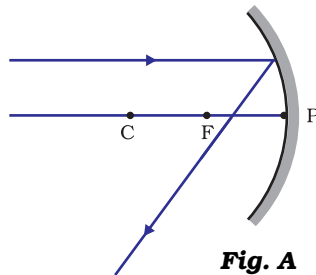

Fig. A

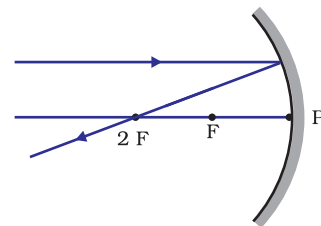

Fig. B

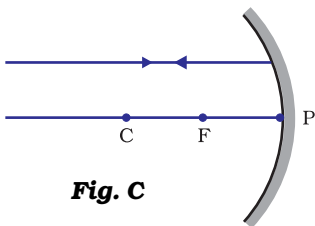

Fig. C

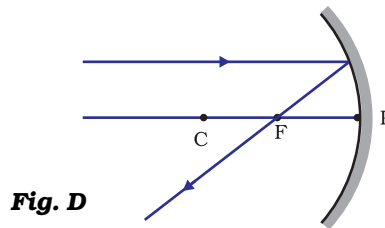

Fig. D

- (a) Fig. A
- (b) Fig. B
- (c) Fig. C
- (d) Fig. D

17. Which of the following ray diagrams is correct for the ray of light incident on a lens shown in Fig. 10.7?

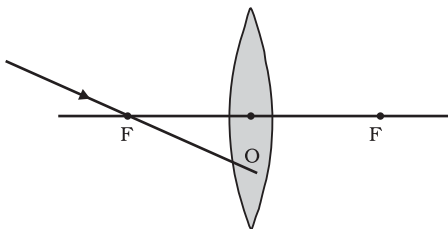

Fig. 10.7

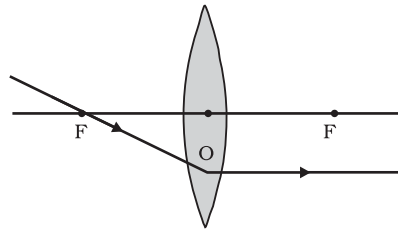

Fig. A

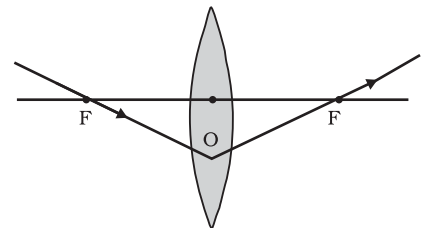

Fig. B

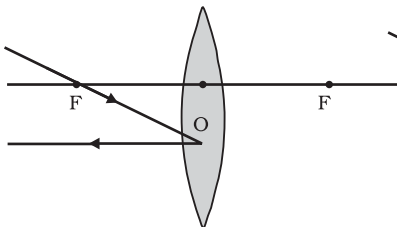

Fig. C

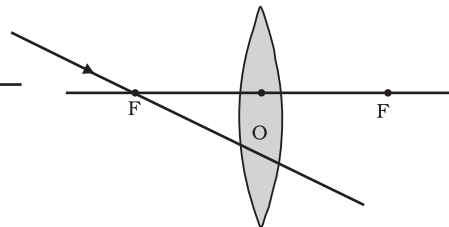

Fig. D

- (a) Fig. A.
- (b) Fig. B.
- (c) Fig. C.
- (d) Fig. D.

- 18.** A child is standing in front of a magic mirror. She finds the image of her head bigger, the middle portion of her body of the same size and that of the legs smaller. The following is the order of combinations for the magic mirror from the top.
- (a) Plane, convex and concave
 - (b) Convex, concave and plane
 - (c) Concave, plane and convex
 - (d) Convex, plane and concave
- 19.** In which of the following, the image of an object placed at infinity will be highly diminished and point sized?
- (a) Concave mirror only
 - (b) Convex mirror only
 - (c) Convex lens only
 - (d) Concave mirror, convex mirror, concave lens and convex lens

Short Answer Questions

- 20.** Identify the device used as a spherical mirror or lens in following cases, when the image formed is virtual and erect in each case.
- (a) Object is placed between device and its focus, image formed is enlarged and behind it.
 - (b) Object is placed between the focus and device, image formed is enlarged and on the same side as that of the object.
 - (c) Object is placed between infinity and device, image formed is diminished and between focus and optical centre on the same side as that of the object.
 - (d) Object is placed between infinity and device, image formed is diminished and between pole and focus, behind it.
- 21.** Why does a light ray incident on a rectangular glass slab immersed in any medium emerges parallel to itself? Explain using a diagram.
- 22.** A pencil when dipped in water in a glass tumbler appears to be bent at the interface of air and water. Will the pencil appear to be bent to the same extent, if instead of water we use liquids like, kerosene or turpentine. Support your answer with reason.
- 23.** How is the refractive index of a medium related to the speed of light? Obtain an expression for refractive index of a medium with respect to another in terms of speed of light in these two media?
- 24.** Refractive index of diamond with respect to glass is 1.6 and absolute refractive index of glass is 1.5. Find out the absolute refractive index of diamond.

- 25.** A convex lens of focal length 20 cm can produce a magnified virtual as well as real image. Is this a correct statement? If yes, where shall the object be placed in each case for obtaining these images?
- 26.** Sudha finds out that the sharp image of the window pane of her science laboratory is formed at a distance of 15 cm from the lens. She now tries to focus the building visible to her outside the window instead of the window pane without disturbing the lens. In which direction will she move the screen to obtain a sharp image of the building? What is the approximate focal length of this lens?
- 27.** How are power and focal length of a lens related? You are provided with two lenses of focal length 20 cm and 40 cm respectively. Which lens will you use to obtain more convergent light?
- 28.** Under what condition in an arrangement of two plane mirrors, incident ray and reflected ray will always be parallel to each other, whatever may be angle of incidence. Show the same with the help of diagram.
- 29.** Draw a ray diagram showing the path of rays of light when it enters with oblique incidence (i) from air into water; (ii) from water into air.

Long Answer Questions

- 30.** Draw ray diagrams showing the image formation by a concave mirror when an object is placed
- (a) between pole and focus of the mirror
 - (b) between focus and centre of curvature of the mirror
 - (c) at centre of curvature of the mirror
 - (d) a little beyond centre of curvature of the mirror
 - (e) at infinity
- 31.** Draw ray diagrams showing the image formation by a convex lens when an object is placed
- (a) between optical centre and focus of the lens
 - (b) between focus and twice the focal length of the lens
 - (c) at twice the focal length of the lens
 - (d) at infinity
 - (e) at the focus of the lens
- 32.** Write laws of refraction. Explain the same with the help of ray diagram, when a ray of light passes through a rectangular glass slab.

- 33.** Draw ray diagrams showing the image formation by a concave lens when an object is placed
- (a) at the focus of the lens
 - (b) between focus and twice the focal length of the lens
 - (c) beyond twice the focal length of the lens
- 34.** Draw ray diagrams showing the image formation by a convex mirror when an object is placed
- (a) at infinity
 - (b) at finite distance from the mirror
- 35.** The image of a candle flame formed by a lens is obtained on a screen placed on the other side of the lens. If the image is three times the size of the flame and the distance between lens and image is 80 cm, at what distance should the candle be placed from the lens? What is the nature of the image at a distance of 80 cm and the lens?
- 36.** Size of image of an object by a mirror having a focal length of 20 cm is observed to be reduced to $\frac{1}{3}$ rd of its size. At what distance the object has been placed from the mirror? What is the nature of the image and the mirror?
- 37.** Define power of a lens. What is its unit? One student uses a lens of focal length 50 cm and another of -50 cm. What is the nature of the lens and its power used by each of them?
- 38.** A student focussed the image of a candle flame on a white screen using a convex lens. He noted down the position of the candle screen and the lens as under
- Position of candle = 12.0 cm
- Position of convex lens = 50.0 cm
- Position of the screen = 88.0 cm
- (i) What is the focal length of the convex lens?
 - (ii) Where will the image be formed if he shifts the candle towards the lens at a position of 31.0 cm?
 - (iii) What will be the nature of the image formed if he further shifts the candle towards the lens?
 - (iv) Draw a ray diagram to show the formation of the image in case (iii) as said above.



CHAPTER 11

The Human Eye and the Colourful World

Multiple Choice Questions

1. A person cannot see distinctly objects kept beyond 2 m. This defect can be corrected by using a lens of power
 - (a) + 0.5 D
 - (b) - 0.5 D
 - (c) + 0.2 D
 - (d) - 0.2 D
2. A student sitting on the last bench can read the letters written on the blackboard but is not able to read the letters written in his text book. Which of the following statements is correct?
 - (a) The near point of his eyes has receded away
 - (b) The near point of his eyes has come closer to him
 - (c) The far point of his eyes has come closer to him
 - (d) The far point of his eyes has receded away
3. A prism ABC (with BC as base) is placed in different orientations. A narrow beam of white light is incident on the prism as shown in Figure 11.1. In which of the following cases, after dispersion, the third colour from the top corresponds to the colour of the sky?
 - (a) (i)
 - (b) (ii)
 - (c) (iii)
 - (d) (iv)

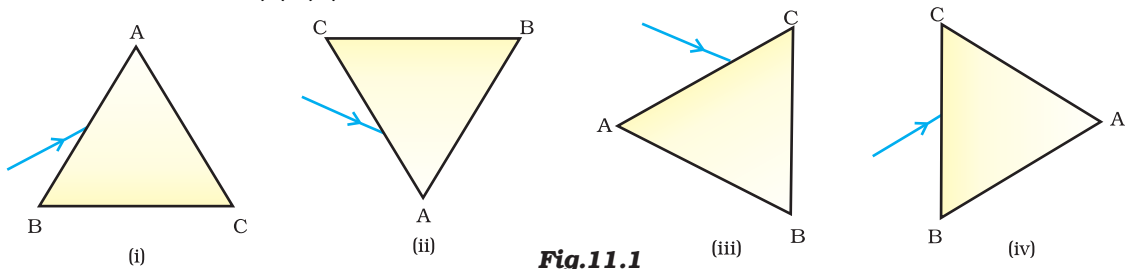

Fig.11.1

- 4.** At noon the sun appears white as
- (a) light is least scattered
 - (b) all the colours of the white light are scattered away
 - (c) blue colour is scattered the most
 - (d) red colour is scattered the most
- 5.** Which of the following phenomena of light are involved in the formation of a rainbow?
- (a) Reflection, refraction and dispersion
 - (b) Refraction, dispersion and total internal reflection
 - (c) Refraction, dispersion and internal reflection
 - (d) Dispersion, scattering and total internal reflection
- 6.** Twinkling of stars is due to atmospheric
- (a) dispersion of light by water droplets
 - (b) refraction of light by different layers of varying refractive indices
 - (c) scattering of light by dust particles
 - (d) internal reflection of light by clouds
- 7.** The clear sky appears blue because
- (a) blue light gets absorbed in the atmosphere
 - (b) ultraviolet radiations are absorbed in the atmosphere
 - (c) violet and blue lights get scattered more than lights of all other colours by the atmosphere
 - (d) light of all other colours is scattered more than the violet and blue colour lights by the atmosphere
- 8.** Which of the following statements is correct regarding the propagation of light of different colours of white light in air?
- (a) Red light moves fastest
 - (b) Blue light moves faster than green light
 - (c) All the colours of the white light move with the same speed
 - (d) Yellow light moves with the mean speed as that of the red and the violet light
- 9.** The danger signals installed at the top of tall buildings are red in colour. These can be easily seen from a distance because among all other colours, the red light
- (a) is scattered the most by smoke or fog
 - (b) is scattered the least by smoke or fog
 - (c) is absorbed the most by smoke or fog
 - (d) moves fastest in air

- 10.** Which of the following phenomena contributes significantly to the reddish appearance of the sun at sunrise or sunset?
- (a) Dispersion of light
 - (b) Scattering of light
 - (c) Total internal reflection of light
 - (d) Reflection of light from the earth
- 11.** The bluish colour of water in deep sea is due to
- (a) the presence of algae and other plants found in water
 - (b) reflection of sky in water
 - (c) scattering of light
 - (d) absorption of light by the sea
- 12.** When light rays enter the eye, most of the refraction occurs at the
- (a) crystalline lens
 - (b) outer surface of the cornea
 - (c) iris
 - (d) pupil
- 13.** The focal length of the eye lens increases when eye muscles
- (a) are relaxed and lens becomes thinner
 - (b) contract and lens becomes thicker
 - (c) are relaxed and lens becomes thicker
 - (d) contract and lens becomes thinner
- 14.** Which of the following statement is correct?
- (a) A person with myopia can see distant objects clearly
 - (b) A person with hypermetropia can see nearby objects clearly
 - (c) A person with myopia can see nearby objects clearly
 - (d) A person with hypermetropia cannot see distant objects clearly

Short Answer Questions

- 15.** Draw ray diagrams each showing (i) myopic eye and (ii) hypermetropic eye.
- 16.** A student sitting at the back of the classroom cannot read clearly the letters written on the blackboard. What advice will a doctor give to her? Draw ray diagram for the correction of this defect.
- 17.** How are we able to see nearby and also the distant objects clearly?

- 18.** A person needs a lens of power -4.5 D for correction of her vision.
- (a) What kind of defect in vision is she suffering from?
 - (b) What is the focal length of the corrective lens?
 - (c) What is the nature of the corrective lens?
- 19.** How will you use two identical prisms so that a narrow beam of white light incident on one prism emerges out of the second prism as white light? Draw the diagram.
- 20.** Draw a ray diagram showing the dispersion through a prism when a narrow beam of white light is incident on one of its refracting surfaces. Also indicate the order of the colours of the spectrum obtained.
- 21.** Is the position of a star as seen by us its true position? Justify your answer.
- 22.** Why do we see a rainbow in the sky only after rainfall?
- 23.** Why is the colour of the clear sky blue?
- 24.** What is the difference in colours of the Sun observed during sunrise/sunset and noon? Give explanation for each.

Long Answer Questions

- 25.** Explain the structure and functioning of Human eye. How are we able to see nearby as well as distant objects?
- 26.** When do we consider a person to be myopic or hypermetropic? Explain using diagrams how the defects associated with myopic and hypermetropic eye can be corrected?
- 27.** Explain the refraction of light through a triangular glass prism using a labelled ray diagram. Hence define the angle of deviation.
- 28.** How can we explain the reddish appearance of sun at sunrise or sunset? Why does it not appear red at noon?
- 29.** Explain the phenomenon of dispersion of white light through a glass prism, using suitable ray diagram.
- 30.** How does refraction take place in the atmosphere? Why do stars twinkle but not the planets?

CHAPTER 12

Electricity

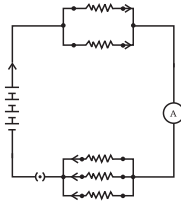

Multiple Choice Questions

1. A cell, a resistor, a key and ammeter are arranged as shown in the circuit diagrams of Figure 12.1. The current recorded in the ammeter will be

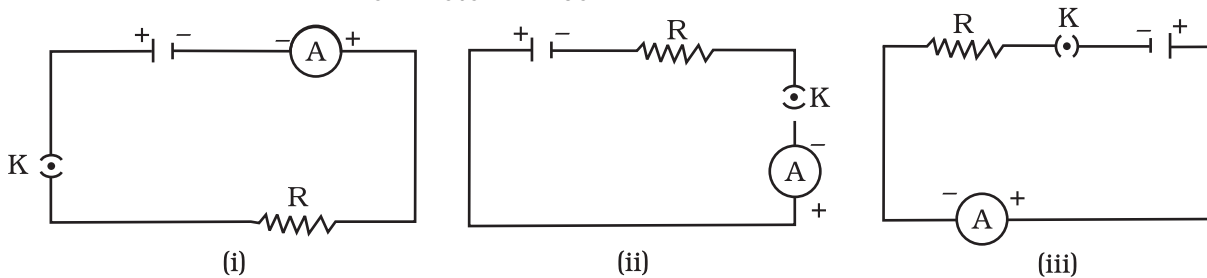

Fig. 12.1

- (a) maximum in (i)
 (b) maximum in (ii)
 (c) maximum in (iii)
 (d) the same in all the cases
2. In the following circuits (Figure 12.2), heat produced in the resistor or combination of resistors connected to a 12 V battery will be

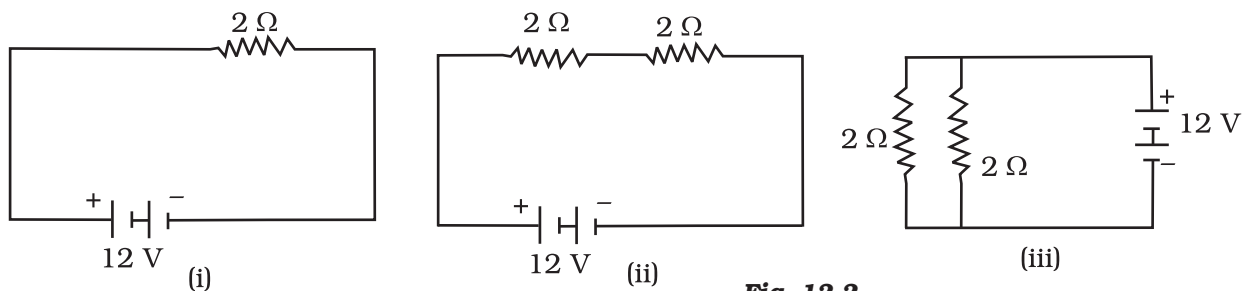

Fig. 12.2

- (a) same in all the cases
 (b) minimum in case (i)
 (c) maximum in case (ii)
 (d) maximum in case (iii)

3. Electrical resistivity of a given metallic wire depends upon
- its length
 - its thickness
 - its shape
 - nature of the material
4. A current of 1 A is drawn by a filament of an electric bulb. Number of electrons passing through a cross section of the filament in 16 seconds would be roughly
- 10^{20}
 - 10^{16}
 - 10^{18}
 - 10^{23}
5. Identify the circuit (Figure 12.3) in which the electrical components have been properly connected.

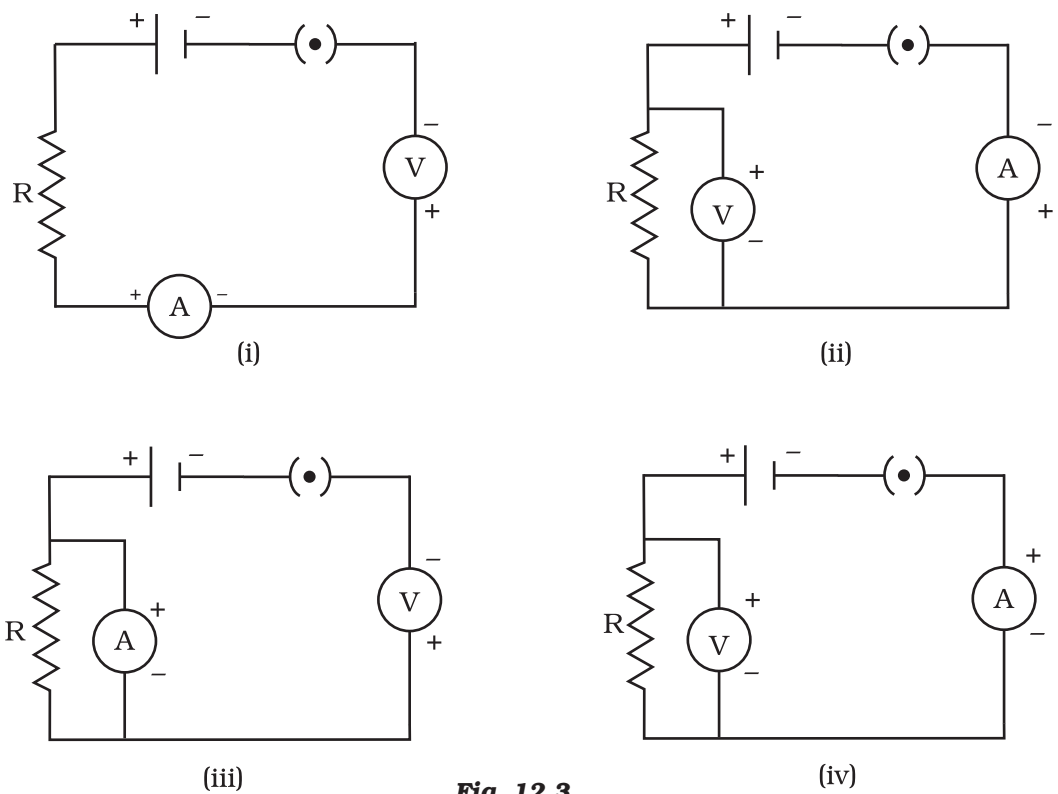
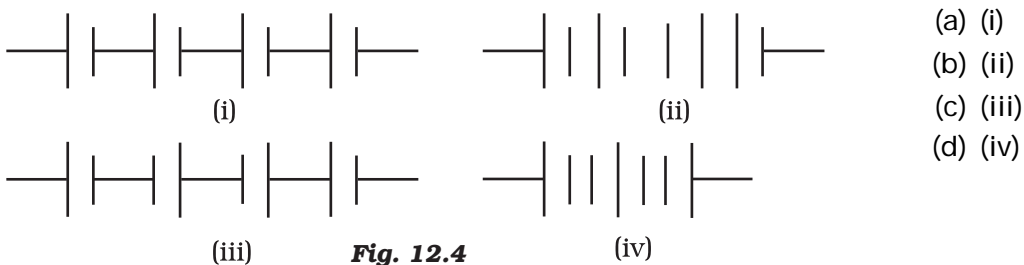

Fig. 12.3

- (i)
- (ii)
- (iii)
- (iv)

6. What is the maximum resistance which can be made using five resistors each of $1/5 \Omega$?
- (a) $1/5 \Omega$
 (b) 10Ω
 (c) 5Ω
 (d) 1Ω
7. What is the minimum resistance which can be made using five resistors each of $1/5 \Omega$?
- (a) $1/5 \Omega$
 (b) $1/25 \Omega$
 (c) $1/10 \Omega$
 (d) 25Ω
8. The proper representation of series combination of cells (Figure 12.4) obtaining maximum potential is



9. Which of the following represents voltage?
- (a) $\frac{\text{Work done}}{\text{Current} \times \text{Time}}$
 (b) $\frac{\text{Work done}}{\text{Charge}}$
 (c) $\frac{\text{Work done} \times \text{Time}}{\text{Current}}$
 (d) $\frac{\text{Work done}}{\text{Charge} \times \text{Time}}$
10. A cylindrical conductor of length l and uniform area of cross-section A has resistance R . Another conductor of length $2l$ and resistance R of the same material has area of cross section
- (a) $A/2$
 (b) $3A/2$
 (c) $2A$
 (d) $3A$

11. A student carries out an experiment and plots the V-I graph of three samples of nichrome wire with resistances R_1 , R_2 and R_3 respectively (Figure.12.5). Which of the following is true?

- (a) $R_1 = R_2 = R_3$
- (b) $R_1 > R_2 > R_3$
- (c) $R_3 > R_2 > R_1$
- (d) $R_2 > R_3 > R_1$

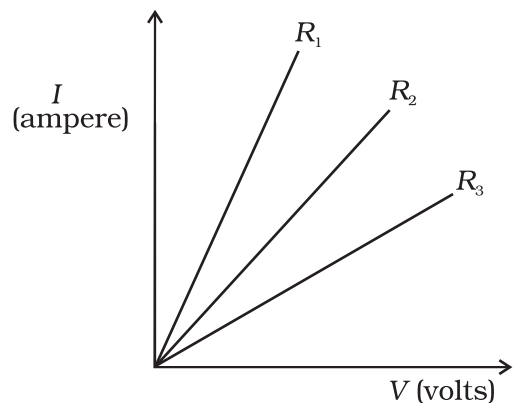

Fig. 12.5

12. If the current I through a resistor is increased by 100% (assume that temperature remains unchanged), the increase in power dissipated will be

- (a) 100 %
- (b) 200 %
- (c) 300 %
- (d) 400 %

13. The resistivity does not change if

- (a) the material is changed
- (b) the temperature is changed
- (c) the shape of the resistor is changed
- (d) both material and temperature are changed

14. In an electrical circuit three incandescent bulbs A, B and C of rating 40 W, 60 W and 100 W respectively are connected in parallel to an electric source. Which of the following is likely to happen regarding their brightness?

- (a) Brightness of all the bulbs will be the same
- (b) Brightness of bulb A will be the maximum
- (c) Brightness of bulb B will be more than that of A
- (d) Brightness of bulb C will be less than that of B

15. In an electrical circuit two resistors of 2Ω and 4Ω respectively are connected in series to a 6 V battery. The heat dissipated by the 4Ω resistor in 5 s will be

- (a) 5 J
- (b) 10 J
- (c) 20 J
- (d) 30 J

16. An electric kettle consumes 1 kW of electric power when operated at 220 V. A fuse wire of what rating must be used for it?

- (a) 1 A
- (b) 2 A
- (c) 4 A
- (d) 5 A

- 17.** Two resistors of resistance $2\ \Omega$ and $4\ \Omega$ when connected to a battery will have
- same current flowing through them when connected in parallel
 - same current flowing through them when connected in series
 - same potential difference across them when connected in series
 - different potential difference across them when connected in parallel
- 18.** Unit of electric power may also be expressed as
- volt ampere
 - kilowatt hour
 - watt second
 - joule second

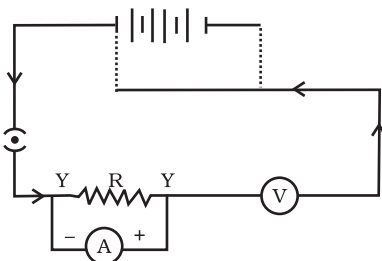

Fig. 12.6

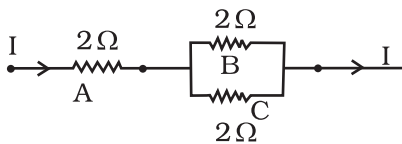

Fig. 12.7

Short Answer Questions

- 19.** A child has drawn the electric circuit to study Ohm's law as shown in Figure 12.6. His teacher told that the circuit diagram needs correction. Study the circuit diagram and redraw it after making all corrections.
- 20.** Three $2\ \Omega$ resistors, A, B and C, are connected as shown in Figure 12.7. Each of them dissipates energy and can withstand a maximum power of 18W without melting. Find the maximum current that can flow through the three resistors?
- 21.** Should the resistance of an ammeter be low or high? Give reason.

- 22.** Draw a circuit diagram of an electric circuit containing a cell, a key, an ammeter, a resistor of $2\ \Omega$ in series with a combination of two resistors ($4\ \Omega$ each) in parallel and a voltmeter across the parallel combination. Will the potential difference across the $2\ \Omega$ resistor be the same as that across the parallel combination of $4\ \Omega$ resistors? Give reason.
- 23.** How does use of a fuse wire protect electrical appliances?
- 24.** What is electrical resistivity? In a series electrical circuit comprising a resistor made up of a metallic wire, the ammeter reads $5\ \text{A}$. The reading of the ammeter decreases to half when the length of the wire is doubled. Why?

- 25.** What is the commercial unit of electrical energy? Represent it in terms of joules.
- 26.** A current of 1 ampere flows in a series circuit containing an electric lamp and a conductor of $5\ \Omega$ when connected to a 10 V battery. Calculate the resistance of the electric lamp.

Now if a resistance of $10\ \Omega$ is connected in parallel with this series combination, what change (if any) in current flowing through $5\ \Omega$ conductor and potential difference across the lamp will take place? Give reason.

- 27.** Why is parallel arrangement used in domestic wiring?
- 28.** B_1 , B_2 and B_3 are three identical bulbs connected as shown in Figure 12.8. When all the three bulbs glow, a current of 3A is recorded by the ammeter A.
- What happens to the glow of the other two bulbs when the bulb B_1 gets fused?
 - What happens to the reading of A_1 , A_2 , A_3 and A when the bulb B_2 gets fused?
 - How much power is dissipated in the circuit when all the three bulbs glow together?

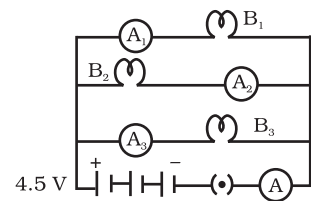

Fig. 12.8

Long Answer Questions

- 29.** Three incandescent bulbs of 100 W each are connected in series in an electric circuit. In another circuit another set of three bulbs of the same wattage are connected in parallel to the same source.
- Will the bulb in the two circuits glow with the same brightness? Justify your answer.
 - Now let one bulb in both the circuits get fused. Will the rest of the bulbs continue to glow in each circuit? Give reason.
- 30.** State Ohm's law? How can it be verified experimentally? Does it hold good under all conditions? Comment.
- 31.** What is electrical resistivity of a material? What is its unit? Describe an experiment to study the factors on which the resistance of conducting wire depends.
- 32.** How will you infer with the help of an experiment that the same current flows through every part of the circuit containing three resistances in series connected to a battery?
- 33.** How will you conclude that the same potential difference (voltage) exists across three resistors connected in a parallel arrangement to a battery?

- 34.** What is Joule's heating effect? How can it be demonstrated experimentally? List its four applications in daily life.
- 35.** Find out the following in the electric circuit given in Figure 12.9
- (a) Effective resistance of two $8\ \Omega$ resistors in the combination
 - (b) Current flowing through $4\ \Omega$ resistor
 - (c) Potential difference across $4\ \Omega$ resistance
 - (d) Power dissipated in $4\ \Omega$ resistor
 - (e) Difference in ammeter readings, if any.

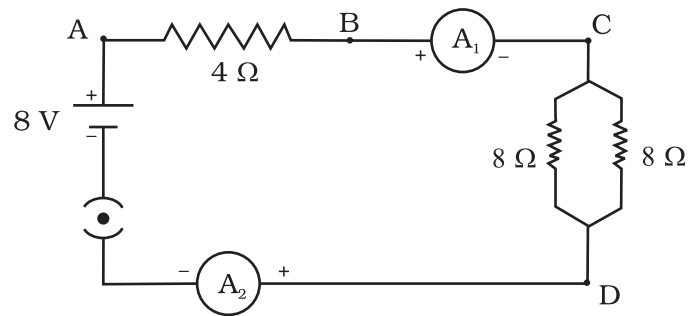
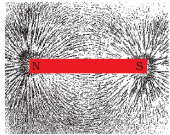

Fig. 12.9

CHAPTER 13

Magnetic Effects of Electric Current



Multiple Choice Questions

1. Choose the incorrect statement from the following regarding magnetic lines of field

- (a) The direction of magnetic field at a point is taken to be the direction in which the north pole of a magnetic compass needle points
- (b) Magnetic field lines are closed curves
- (c) If magnetic field lines are parallel and equidistant, they represent zero field strength
- (d) Relative strength of magnetic field is shown by the degree of closeness of the field lines

2. If the key in the arrangement (Figure 13.1) is taken out (the circuit is made open) and magnetic field lines are drawn over the horizontal plane ABCD, the lines are

- (a) concentric circles
- (b) elliptical in shape
- (c) straight lines parallel to each other
- (d) concentric circles near the point O but of elliptical shapes as we go away from it

3. A circular loop placed in a plane perpendicular to the plane of paper carries a current when the key is ON. The current as seen from points A and B (in the plane of paper and on the axis of the coil) is anti clockwise and clockwise respectively. The magnetic field lines point from B to A. The N-pole of the resultant magnet is on the face close to

- (a) A
- (b) B
- (c) A if the current is small, and B if the current is large
- (d) B if the current is small and A if the current is large

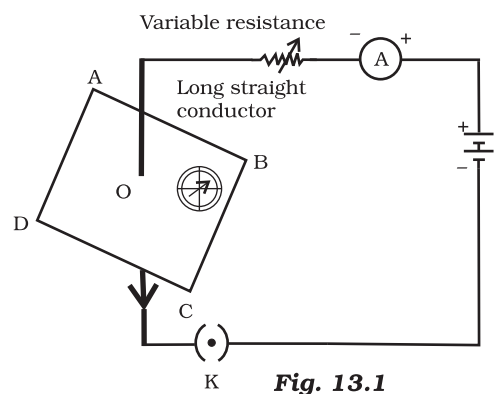

Fig. 13.1

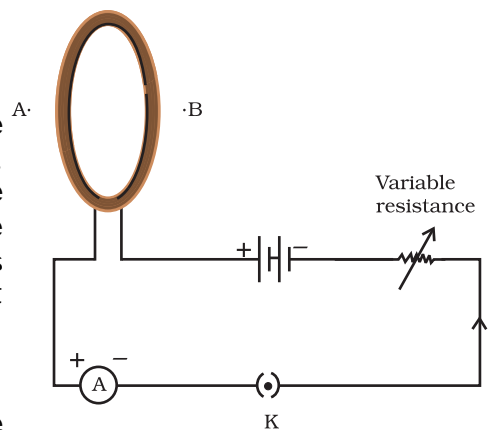

Fig. 13.2

4. For a current in a long straight solenoid N- and S-poles are created at the two ends. Among the following statements, the incorrect statement is
- The field lines inside the solenoid are in the form of straight lines which indicates that the magnetic field is the same at all points inside the solenoid
 - The strong magnetic field produced inside the solenoid can be used to magnetise a piece of magnetic material like soft iron, when placed inside the coil
 - The pattern of the magnetic field associated with the solenoid is different from the pattern of the magnetic field around a bar magnet
 - The N- and S-poles exchange position when the direction of current through the solenoid is reversed

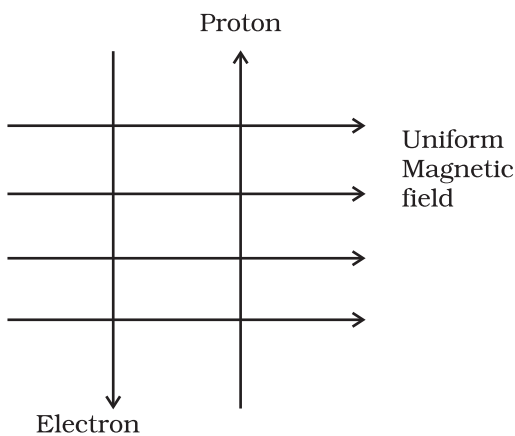

Fig. 13.3

5. A uniform magnetic field exists in the plane of paper pointing from left to right as shown in Figure 13.3. In the field an electron and a proton move as shown. The electron and the proton experience
- forces both pointing into the plane of paper
 - forces both pointing out of the plane of paper
 - forces pointing into the plane of paper and out of the plane of paper, respectively
 - force pointing opposite and along the direction of the uniform magnetic field respectively

6. Commercial electric motors do not use
- an electromagnet to rotate the armature
 - effectively large number of turns of conducting wire in the current carrying coil
 - a permanent magnet to rotate the armature
 - a soft iron core on which the coil is wound

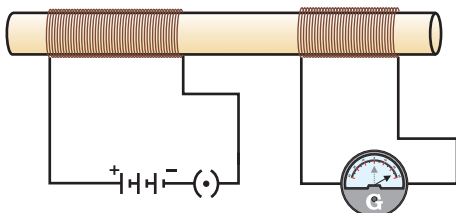

Fig. 13.4

7. In the arrangement shown in Figure 13.4 there are two coils wound on a non-conducting cylindrical rod. Initially the key is not inserted. Then the key is inserted and later removed. Then
- the deflection in the galvanometer remains zero throughout
 - there is a momentary deflection in the galvanometer but it dies out shortly and there is no effect when the key is removed

- (c) there are momentary galvanometer deflections that die out shortly; the deflections are in the same direction
- (d) there are momentary galvanometer deflections that die out shortly; the deflections are in opposite directions
- 8.** Choose the incorrect statement
- (a) Fleming's right-hand rule is a simple rule to know the direction of induced current
- (b) The right-hand thumb rule is used to find the direction of magnetic fields due to current carrying conductors
- (c) The difference between the direct and alternating currents is that the direct current always flows in one direction, whereas the alternating current reverses its direction periodically
- (d) In India, the AC changes direction after every $\frac{1}{50}$ second
- 9.** A constant current flows in a horizontal wire in the plane of the paper from east to west as shown in Figure 13.5. The direction of magnetic field at a point will be North to South
- (a) directly above the wire
- (b) directly below the wire
- (c) at a point located in the plane of the paper, on the north side of the wire
- (d) at a point located in the plane of the paper, on the south side of the wire
- 10.** The strength of magnetic field inside a long current carrying straight solenoid is
- (a) more at the ends than at the centre
- (b) minimum in the middle
- (c) same at all points
- (d) found to increase from one end to the other
- 11.** To convert an AC generator into DC generator
- (a) split-ring type commutator must be used
- (b) slip rings and brushes must be used
- (c) a stronger magnetic field has to be used
- (d) a rectangular wire loop has to be used
- 12.** The most important safety method used for protecting home appliances from short circuiting or overloading is
- (a) earthing
- (b) use of fuse
- (c) use of stabilizers
- (d) use of electric meter

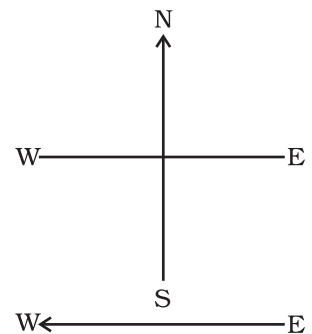

Fig. 13.5

Short Answer Questions

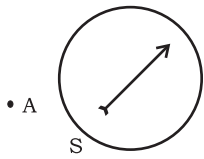

Fig. 13.6

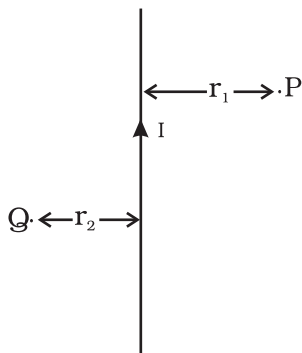

Fig. 13.7

13. A magnetic compass needle is placed in the plane of paper near point A as shown in Figure 13.6. In which plane should a straight current carrying conductor be placed so that it passes through A and there is no change in the deflection of the compass? Under what condition is the deflection maximum and why?
14. Under what conditions permanent electromagnet is obtained if a current carrying solenoid is used? Support your answer with the help of a labelled circuit diagram.
15. AB is a current carrying conductor **in** the plane of the paper as shown in Figure 13.7. What are the directions of magnetic fields produced by it at points P and Q? Given $r_1 > r_2$, where will the strength of the magnetic field be larger?
16. A magnetic compass shows a deflection when placed near a current carrying wire. How will the deflection of the compass get affected if the current in the wire is increased? Support your answer with a reason.
17. It is established that an electric current through a metallic conductor produces a magnetic field around it. Is there a similar magnetic field produced around a thin beam of moving (i) alpha particles, (ii) neutrons? Justify your answer.
18. What does the direction of thumb indicate in the right-hand thumb rule. In what way this rule is different from Fleming's left-hand rule?
19. Meena draws magnetic field lines of field close to the axis of a current carrying circular loop. As she moves away from the centre of the circular loop she observes that the lines keep on diverging. How will you explain her observation.
20. What does the divergence of magnetic field lines near the ends of a current carrying straight solenoid indicate?
21. Name four appliances wherein an electric motor, a rotating device that converts electrical energy to mechanical energy, is used as an important component. In what respect motors are different from generators?
22. What is the role of the two conducting stationary brushes in a simple electric motor?
23. What is the difference between a direct current and an alternating current? How many times does AC used in India change direction in one second?

- 24.** What is the role of fuse, used in series with any electrical appliance? Why should a fuse with defined rating not be replaced by one with a larger rating?

Long Answer Questions

- 25.** Why does a magnetic compass needle pointing North and South in the absence of a nearby magnet get deflected when a bar magnet or a current carrying loop is brought near it. Describe some salient features of magnetic lines of field concept.
- 26.** With the help of a labelled circuit diagram illustrate the pattern of field lines of the magnetic field around a current carrying straight long conducting wire. How is the right hand thumb rule useful to find direction of magnetic field associated with a current carrying conductor?
- 27.** Explain with the help of a labelled diagram the distribution of magnetic field due to a current through a circular loop. Why is it that if a current carrying coil has n turns the field produced at any point is n times as large as that produced by a single turn?
- 28.** Describe the activity that shows that a current-carrying conductor experiences a force perpendicular to its length and the external magnetic field. How does Fleming's left-hand rule help us to find the direction of the force acting on the current carrying conductor?
- 29.** Draw a labelled circuit diagram of a simple electric motor and explain its working. In what way these simple electric motors are different from commercial motors?
- 30.** Explain the phenomenon of electromagnetic induction. Describe an experiment to show that a current is set up in a closed loop when an external magnetic field passing through the loop increases or decreases.
- 31.** Describe the working of an AC generator with the help of a labelled circuit diagram. What changes must be made in the arrangement to convert it to a DC generator?
- 32.** Draw an appropriate schematic diagram showing common domestic circuits and discuss the importance of fuse. Why is it that a burnt out fuse should be replaced by another fuse of identical rating?

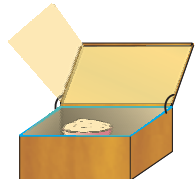

CHAPTER 14

Sources of Energy

Multiple Choice Questions

1. Which of the following is a non-renewable source of energy?
 - (a) Wood
 - (b) Sun
 - (c) Fossil fuels
 - (d) Wind
2. Acid rain happens because
 - (a) sun leads to heating of upper layer of atmosphere
 - (b) burning of fossil fuels release oxides of carbon, nitrogen and sulphur in the atmosphere
 - (c) electrical charges are produced due to friction amongst clouds
 - (d) earth atmosphere contains acids
3. Fuel used in thermal power plants is
 - (a) water
 - (b) uranium
 - (c) biomass
 - (d) fossil fuels
4. In a hydro power plant
 - (a) Potential energy possessed by stored water is converted into electricity
 - (b) Kinetic energy possessed by stored water is converted into potential energy
 - (c) Electricity is extracted from water
 - (d) Water is converted into steam to produce electricity

- 5.** Which is the ultimate source of energy?
- (a) Water
 - (b) Sun
 - (c) Uranium
 - (d) Fossil fuels
- 6.** Which one of the following forms of energy leads to least environmental pollution in the process of its harnessing and utilisation?
- (a) Nuclear energy
 - (b) Thermal energy
 - (c) Solar energy
 - (d) Geothermal energy
- 7.** Ocean thermal energy is due to
- (a) energy stored by waves in the ocean
 - (b) temperature difference at different levels in the ocean
 - (c) pressure difference at different levels in the ocean
 - (d) tides arising out in the ocean
- 8.** The major problem in harnessing nuclear energy is how to
- (a) split nuclei?
 - (b) sustain the reaction?
 - (c) dispose off spent fuel safely?
 - (d) convert nuclear energy into electrical energy?
- 9.** Which part of the solar cooker is responsible for green house effect?
- (a) Coating with black colour inside the box
 - (b) Mirror
 - (c) Glass sheet
 - (d) Outer cover of the solar cooker
- 10.** The main constituent of biogas is
- (a) methane
 - (b) carbon dioxide
 - (c) hydrogen
 - (d) hydrogen sulphide
- 11.** The power generated in a windmill
- (a) is more in rainy season since damp air would mean more air mass hitting the blades
 - (b) depends on the height of the tower
 - (c) depends on wind velocity
 - (d) can be increased by planting tall trees close to the tower

- 12.** Choose the correct statement
- (a) Sun can be taken as an inexhaustible source of energy
 - (b) There is infinite storage of fossil fuel inside the earth
 - (c) Hydro and wind energy plants are non polluting sources of energy
 - (d) Waste from a nuclear power plant can be easily disposed off
- 13.** In a hydroelectric power plant more electrical power can be generated if water falls from a greater height because
- (a) its temperature increases
 - (b) larger amount of potential energy is converted into kinetic energy
 - (c) the electricity content of water increases with height
 - (d) more water molecules dissociate into ions
- 14.** Choose the incorrect statement regarding wind power
- (a) It is expected to harness wind power to minimum in open space
 - (b) The potential energy content of wind blowing at high altitudes is the source of wind power
 - (c) Wind hitting at the blades of a windmill causes them to rotate. The rotation thus achieved can be utilised further
 - (d) One possible method of utilising the energy of rotational motion of the blades of a windmill is to run the turbine of an electric generator
- 15.** Choose the incorrect statement
- (a) We are encouraged to plant more trees so as to ensure clean environment and also provide bio-mass fuel
 - (b) Gobar-gas is produced when crops, vegetable wastes etc., decompose in the absence of oxygen
 - (c) The main ingredient of bio-gas is ethane and it gives a lot of smoke and also produces a lot of residual ash
 - (d) Bio-mass is a renewable source of energy

Short Answer Questions

- 16.** Why is there a need to harness non-conventional sources of energy? Give two main reasons.
- 17.** Write two different ways of harnessing energy from ocean.
- 18.** What steps would you suggest to minimise environmental pollution caused by burning of fossil fuels?

- 19.** What is the role of a plane mirror and a glass sheet in a solar cooker?
- 20.** Mention three advantages of a solar cell?
- 21.** What is biomass? What can be done to obtain bio-energy using biomass?
- 22.** What are the limitations in obtaining energy from wind?

Long Answer Questions

- 23.** Which is the process used to harness nuclear energy these days? Explain it briefly.
- 24.** How can solar energy be harnessed? Mention any two limitations in using solar energy. How are these limitations overcome?
- 25.** Make a list of conventional and non-conventional sources of energy. Give a brief description of harnessing one non-conventional source of energy.
- 26.** Why is there a need for harnessing non-conventional sources of energy? How can energy be harnessed from the sea in different ways?
- 27.** What are the environmental consequences of using fossil fuels? Suggest the steps to minimise the pollution caused by various sources of energy including non-conventional sources of energy.
- 28.** Energy from various sources is considered to have been derived from the sun. Do you agree? Justify your answer.
- 29.** What is biomass? Explain the principle and working of a biogas plant using a labelled schematic diagram.